

Optional equipment:

Contrappeso divisibile con scarico automatico
Divisible counterweight with automatic unloading

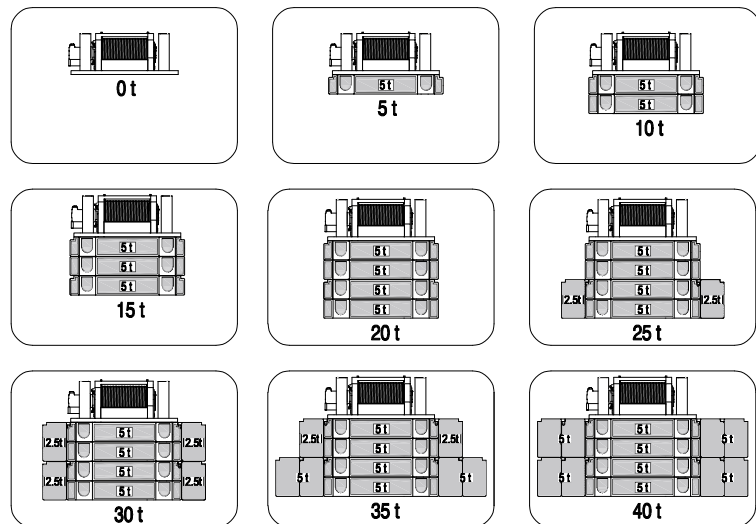

Bilancino di sollevamento da 5,5 m
5,5 m lift spreader beams

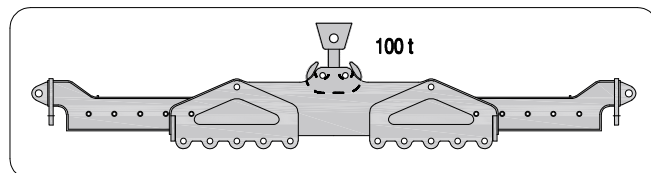

Argano principale
Primary winch

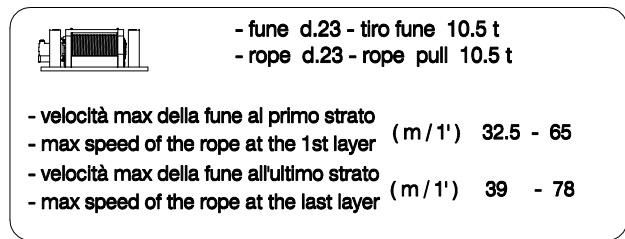

Testa del braccio inclinabile in quattro posizioni
Four position reclinable boom head

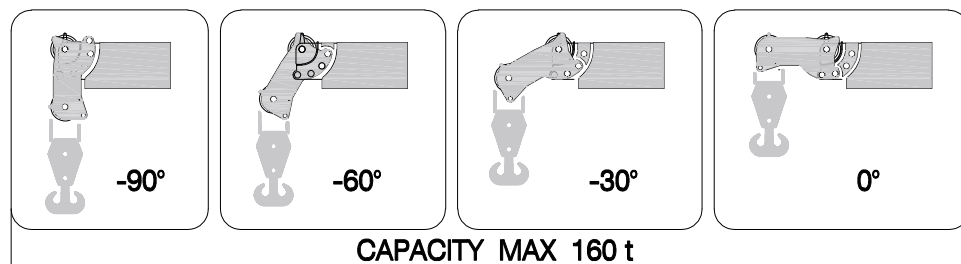

Supporto gancio da 0,7 m per testa del braccio inclinabile
0,7 m hook or pulley for reclinable boom head

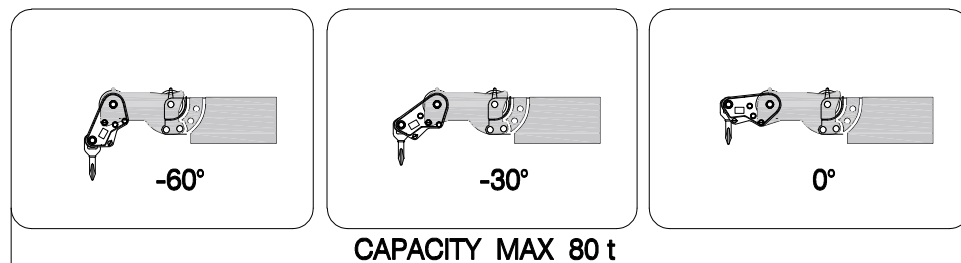

Supporto gancio da 1,7 m per testa del braccio inclinabile
1,7 m hook or pulley for reclinable boom head

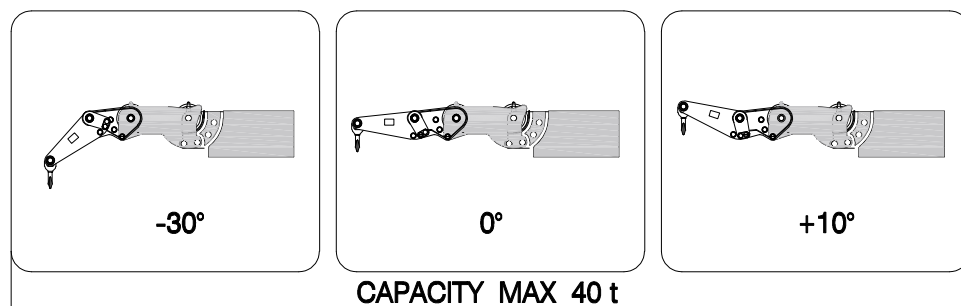

Bozzelli a gancio di varie capacità
Hook blocks of various capacities

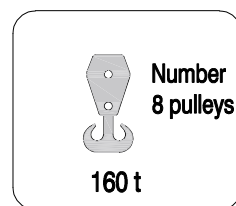
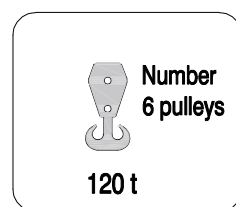
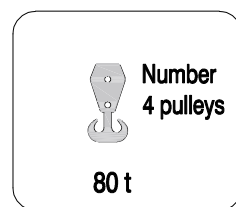
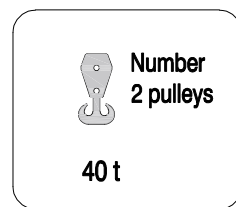

IDROGRU
CRANE

KT 300.26 S

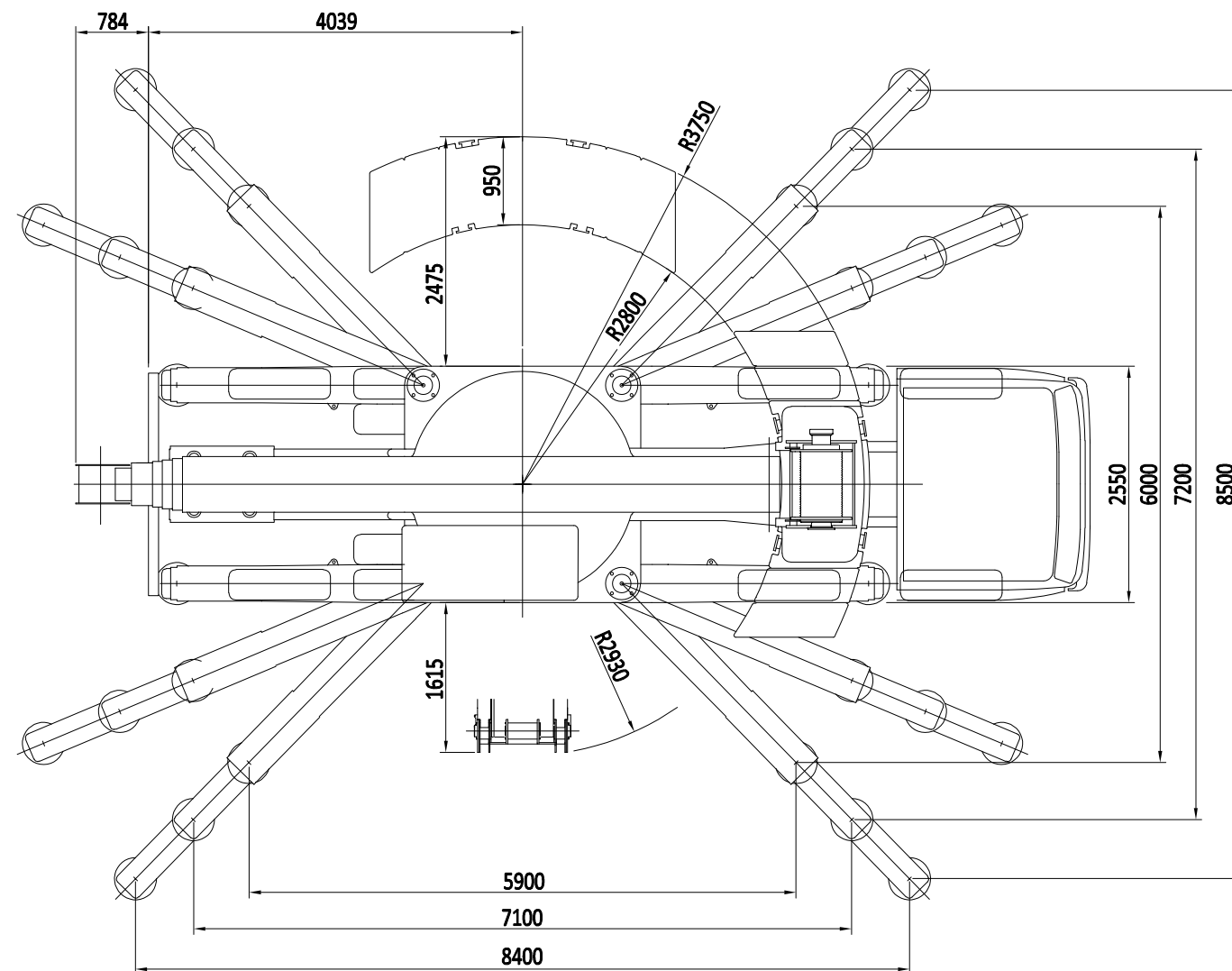
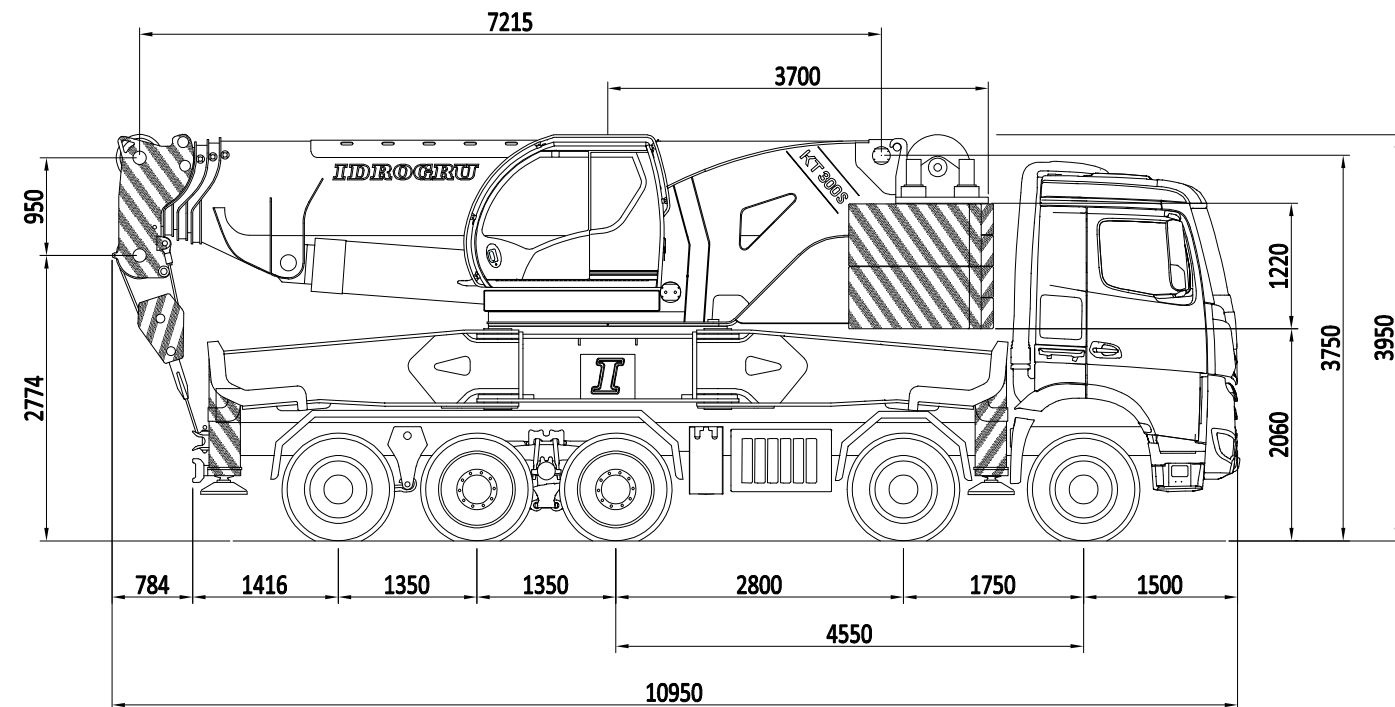

Le capacità di sollevamento nell' area strutturale si basano su DIN 15018 part 3 / FEM 5.004 / EN 13000
The lifting capacities in the structural area are based on DIN 15018 part 3 / FEM 5.004 / EN 13000

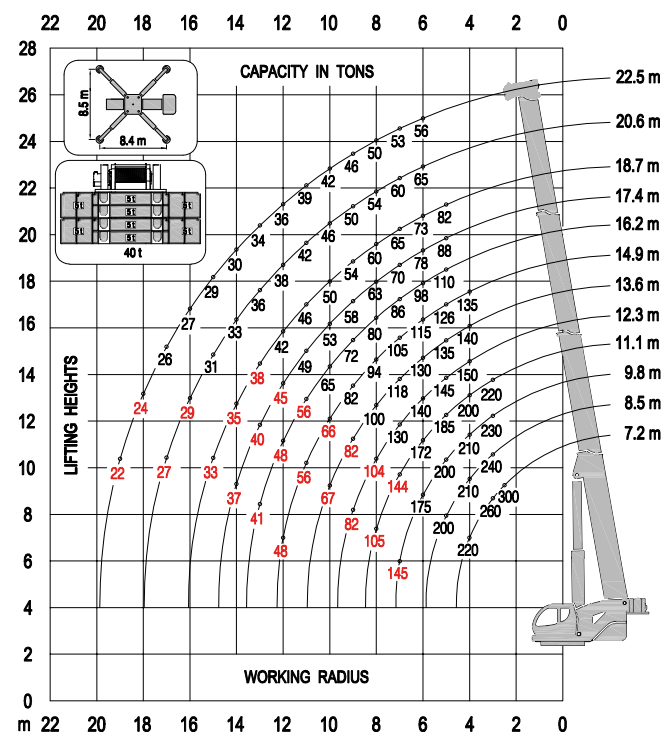
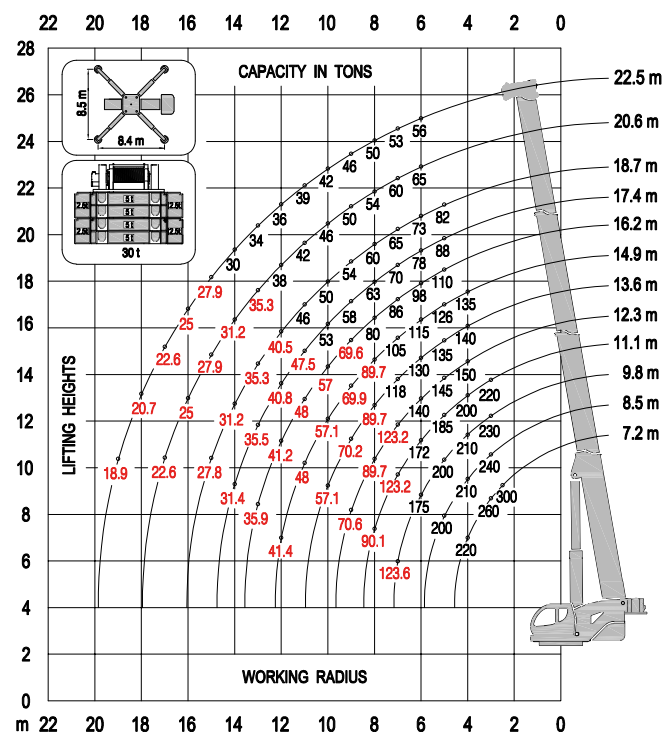
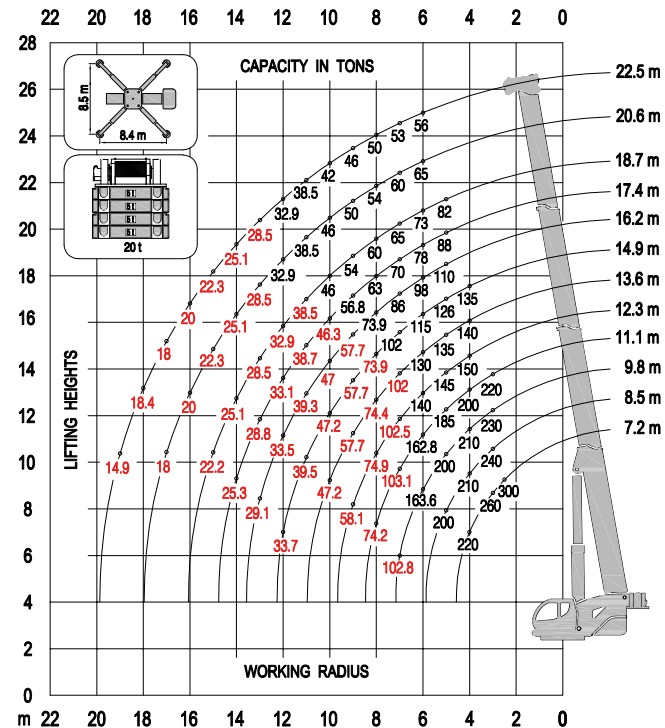
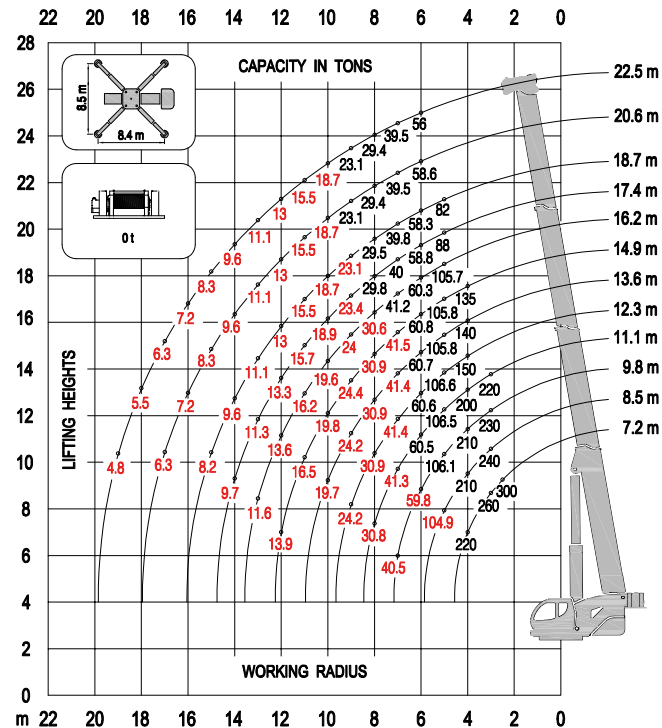

Configurazione in ordine di marcia:
Configuration in running order:

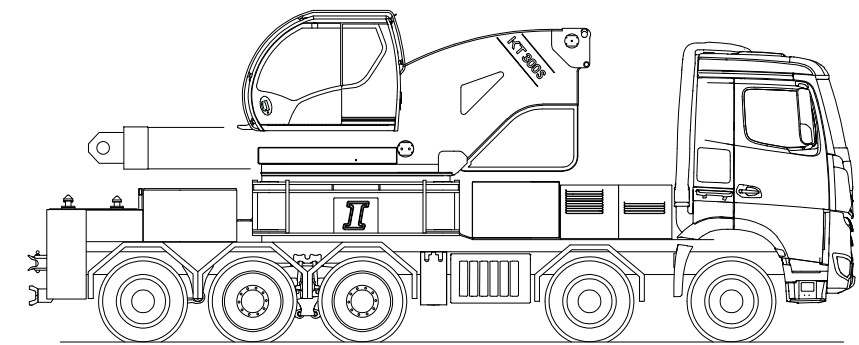

Senza argano, braccio e stabilizzatori : peso tot. 32.000 Kg
Without winch, boom and outriggers : total weight 32.000 Kg.

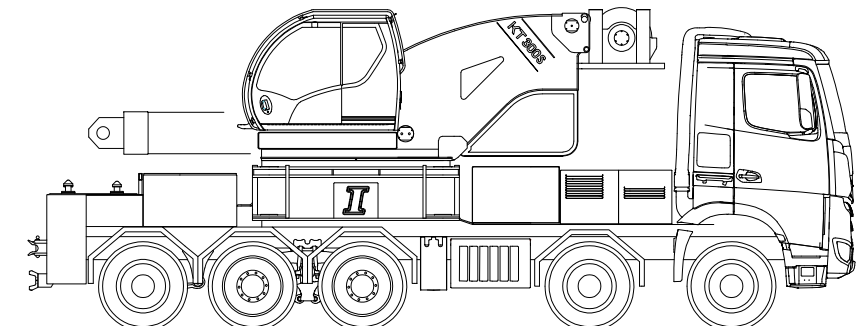

Senza braccio e stabilizzatori posteriori : peso tot. 40.000 Kg
Without boom and rear outriggers : total weight 40.000 Kg.

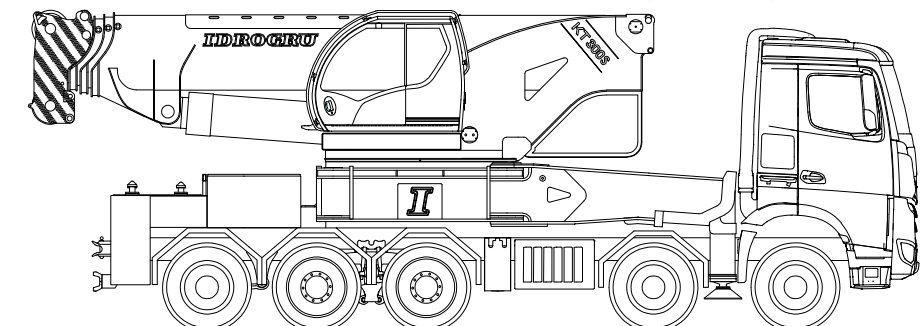

Senza stabilizzatori e argano : peso tot. 44.000 Kg
Without outriggers and winch : total weight 44.000 Kg.

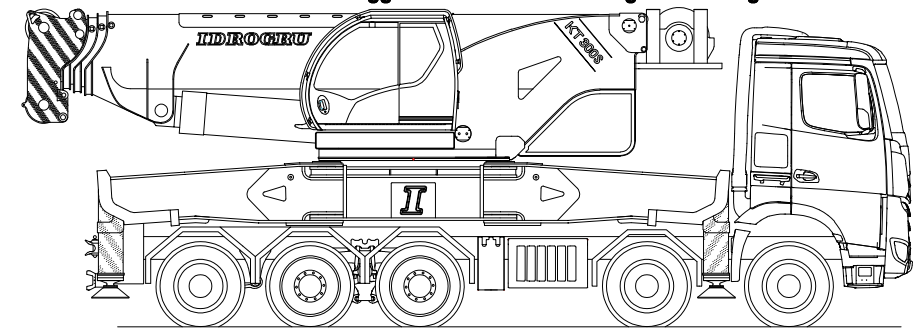

Gru completa : peso tot. 54.000 Kg
Complete Crane : total weight 54.000 Kg.

Max Payload: 160 t